

Sector 2.



aspect 



Aspect Design.

Clarity of purpose and design refinement have resulted in a system that truly reflects the needs of a flexible workplace.



The Aspect Design process explores every opportunity. Every detail is essential.

All materials and aspects of the design process are considered, taking into account user experience, durability, sustainability and environmental outcomes.

Our in-house design team and local manufacturing work closely together as one team. Open communication throughout any design process is key to success, ensuring constructive feedback, engineering efficiencies and quick resolution of any constraints.

Through a collaboration of industry minds, Sector 2 has been designed to challenge the status quo.

In response to the need for increased flexibility in the workplace, Aspect Design has created the Sector 2 table system. A simple kit-of-parts enables the sub-frame and supporting components to span greater distances, while providing uncompromised stability and structural integrity.

To maintain a consistent design language with its stablemate, the new range is an evolution of the original Sector table. It can not only be built in significantly larger configurations, but also accommodate a wider range of work settings within an agile workplace.



Suited to your workplace.

A furniture system that redefines what is possible in table design.



A system that favours flexibility. A system for people at work.

Sector 2 is an innovative table system that is defined not by traditional constraints, but by workplace freedom, large-span surfaces and flexible configurations.

It was designed with people in mind. With table or leaner formats available, it can also be tailored for any space – by colour, size, configuration and accessories.

The system was created to cater for all working styles, whether grabbing a coffee, workshopping, or gathering with your team.



The workplace connection.

Sector 2's design aesthetic, form and system of parts promote a sense of connection between people and their workplace. Attention to detail makes people feel valued.

A feeling of connection encourages not only engagement and culture, but also productivity – an essential platform to nurture social interaction and create a considered and efficient space – whether seated or standing.





Freedom and form.

Sector 2 pairs acuity with integrity through the use of seamless aluminium forms and engineering.

The refined, one-piece extruded sub-frame supports four-metre tops with only four legs. This long-span structure not only maximises seating positions around the table, but also grants workpoint freedom and workplace flow.

It is this clean form that gives Sector 2 an elegant, minimalist aesthetic along with its greater versatility.

The Sector 2 system provides the ultimate platform to host large meetings, as well as spontaneous team collaboration or workshop sessions.

Form meets function.



An intuitive glide at the base of each leg allows for easy height adjustment and levelling.



Structural integrity

Sector's timber legs are positioned seamlessly along the supporting sub-frame using a clip-in casting. On large-format tables that extend beyond four metres, this feature provides further structural integrity to the sub-frame extrusion.



Designed for maximum connectivity.



A power rail located underneath the tabletop allows for concealed connectivity.

Seamless power and data reticulation

The slim, angular leg has a removable cap for concealing cables, creating a refined and elegant look. Power boxes, Floorsight pucks and other facilities are serviced without unsightly cables or umbilical cords.



The power cables can be fully integrated into the tabletop with a pivoting cover that conceals power and USB outlets when not in use.

The cable tray sits flush beneath the tabletop and swings down for easy cable access and management.



Power, data and cable management accessories

- 01. Floorsight
- 02. Above-desk power
- 03. Sector power box (in-desk power)
- 04. Below-desk power outlet
- 05. Sector cable tray
- 06. Sector through-leg power reticulation

Augmented to suit your needs.



We have an extensive range of accessories designed for you to build your ideal workbench.

- 01. Push-on Side screen
- 02. Drop-in Slide screen
- 03. Raised shelf with bookends
- 04. Paper tray
- 05. Planter
- 06. Monitor arm
- 07. WorkTote
- 08. Pen bucket
- 09. Paper Taco
- 10. WorkTote swivel bracket
- 11. Mobile storage caddy
- 12. Task chair
- 13. Ottoman
- 14. Low stool
- 15. Lighting



Workshop space

Take full advantage of the slide screen system and accessory rails to easily reconfigure this workspace for a flexible workshop or project space.



Drop-down space

A casual work hub accessorised with short-term touchdown scenarios in mind.



Process space

A semi-permanent configuration with assigned workpoints and adjacent meeting or break-out spaces.



Customise Sector 2 to suit your space.



Table and leaner

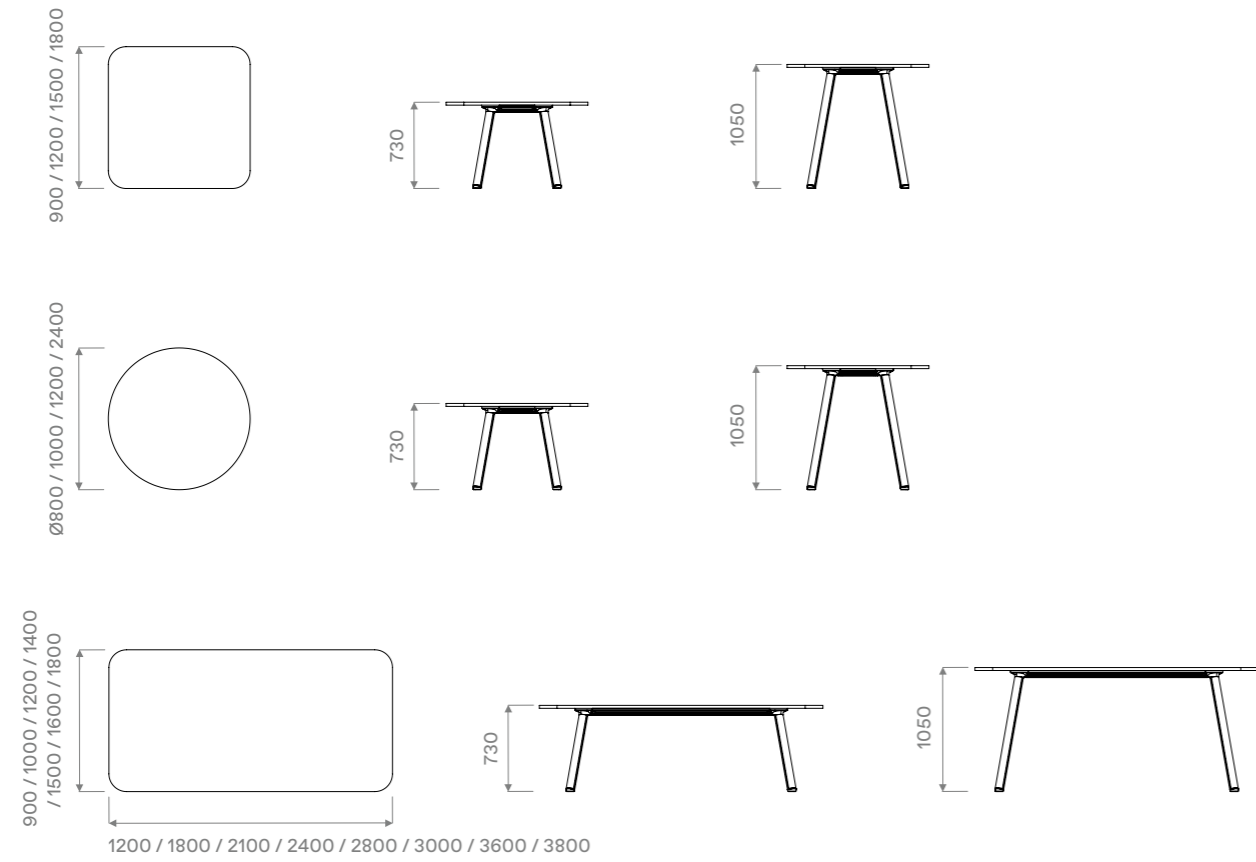

Boardroom table

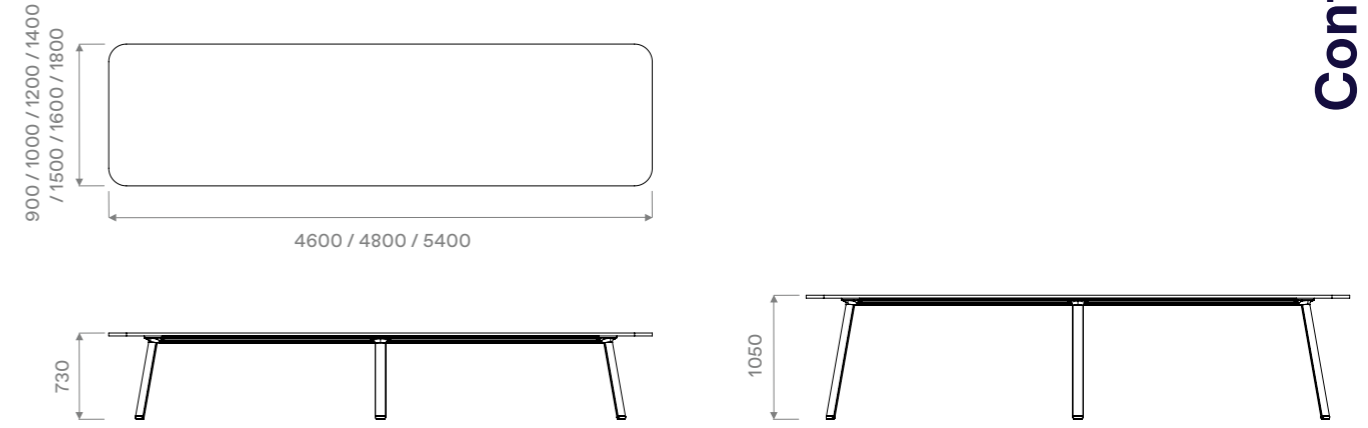

Workbench

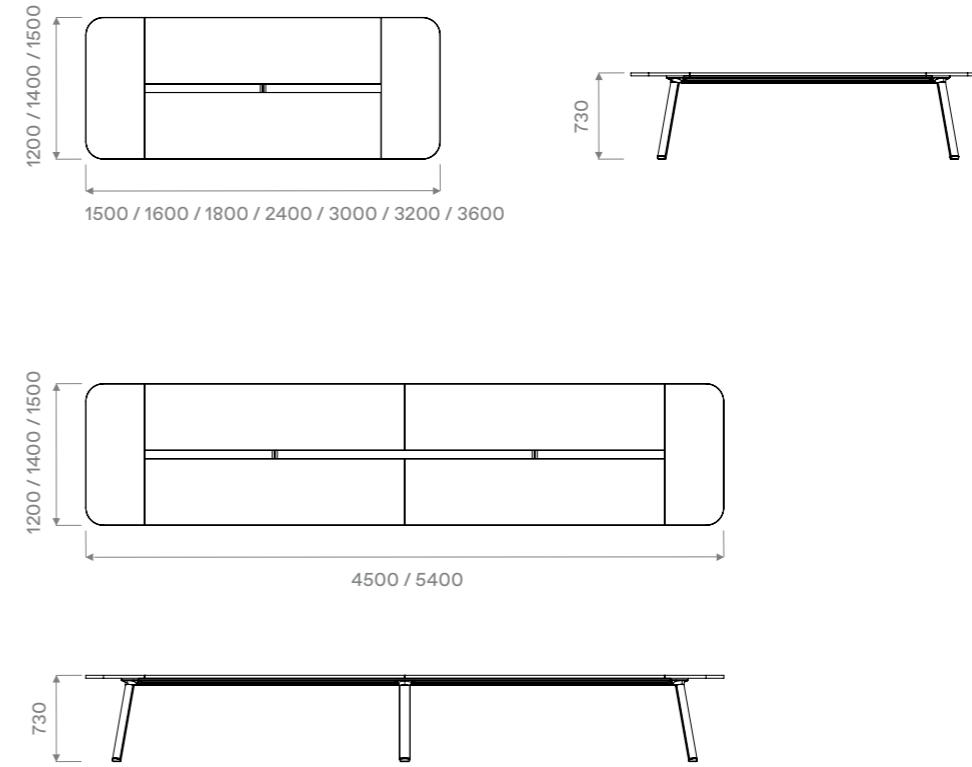

Custom sizes available on request.

Your creative licence.

Create a space with a unique personality and mood!

Worktops:

Sector 2 worktops can be customised with either American Ash, LPL, or veneer.

Legs and understructure:

Powdercoat is available in any colour from the Dulux range. Legs also available in timber and polished aluminium.



Workbench | Colour scheme – Monochromatic

Top finish: Melteca 'Provence Blue'
Legs: Powdercoat Duralloy Solid Matt 'Wedgewood'
Frame: Powdercoat Duralloy Solid Matt 'Wedgewood'



Meeting table | Colour scheme – Minimalist

Top finish: Forbo Marmoleum Solid Black with black edge
Legs: Powdercoat 'Mannex Black'
Frame: Powdercoat 'Mannex Black'



Leaner | Colour scheme – Natural

Top finish: Solid timber 'Ash'
Legs: Solid timber 'Ash'
Frame: Powdercoat 'Mannex Black'

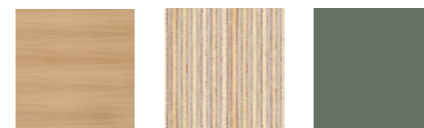
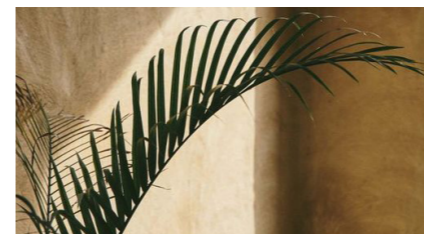

We believe that high-performing spaces enable high-performing people.

We place a person's comfort and ease-of-use at the heart of every product and system we create. Aspect designers and workplace specialists help you create a complete office furniture solution that will inspire and support people in their work every day.

Back in 1982, from a small factory in Auckland, Aspect founder and CEO Richard Simmons made his very first furniture prototypes. Driven by a passion for craft and beautiful engineering, he steadily grew the business and is joined today by his three sons and an expert team of designers, engineers and workplace specialists across New Zealand and Australia. Today, Aspect makes collections at the leading edge of international product design, technology, and workplace best practice.

Our focus on crafted, fully resolved commercial furniture means Aspect collections are trusted by some of the largest public and private organisations around Australasia. With nearly 40 years' experience designing and manufacturing collections for the modern workplace, our office furniture has a reputation for being robust, ergonomic, and comfortable throughout the working day.

We make over 70 per cent of our product range in New Zealand and Australia for true control over design, quality, customisation, and lead times. You receive products quickly and reliably from a quality-assured environment. In addition

to speed and flexibility, local manufacturing also creates a smaller environmental footprint.

Our team of product designers and workplace specialists help you define and select a furniture solution to meet your workplace aspirations and project budget using durable and environmentally sound products.

Direct access to our furniture designers means greater flexibility and control over your solution, as we work from our collections, adapt existing products, or design new components.

Aspect Furniture operates ethical and sustainable business practices. We have certification from Good Environmental Choice Australia (GECA) and Environmental Choice New Zealand (ECNZ), and our products are aligned to the Green Star rating tool. Independent certifiers regularly audit our premises under the ISO 9001 and ISO 14001 quality and environmental management systems. Similarly, the health and safety of our employees is vital to our success, and we are certified to the globally recognised AS/NZS 4801 and ISO 45001 occupational health and safety standards.



Furniture, Fittings
and Flooring
Licence Number
3210076



Quality
ISO 9001



Environment
ISO 14001



Health & Safety
AS/NZS 4801



Showrooms

Sydney
Melbourne
Canberra
Auckland
Wellington
Christchurch

Australia

1800 696 334
infoau@aspectfurniture.com

New Zealand

0800 323 220
info@aspectfurniture.com

aspectfurniture.com

